

Solar Decathlon: A Cleaner Future



Goal: Build a zero net energy efficient home for the Solar Decathlon 2015 Competition.

Team Members: Jason Hwang, Teagan Barnes, Okechi Kwem, Karen Romine, George Agcopra, Ben Khuong, and Zhongyue Luan



The Competition: Comfort Zone

- 71°F to 76°F
- Relative humidity below 60.0%

Innovation

- Dryer heated by hot water
- Hot water tap to kitchen at 180°F
- Radiant ceiling

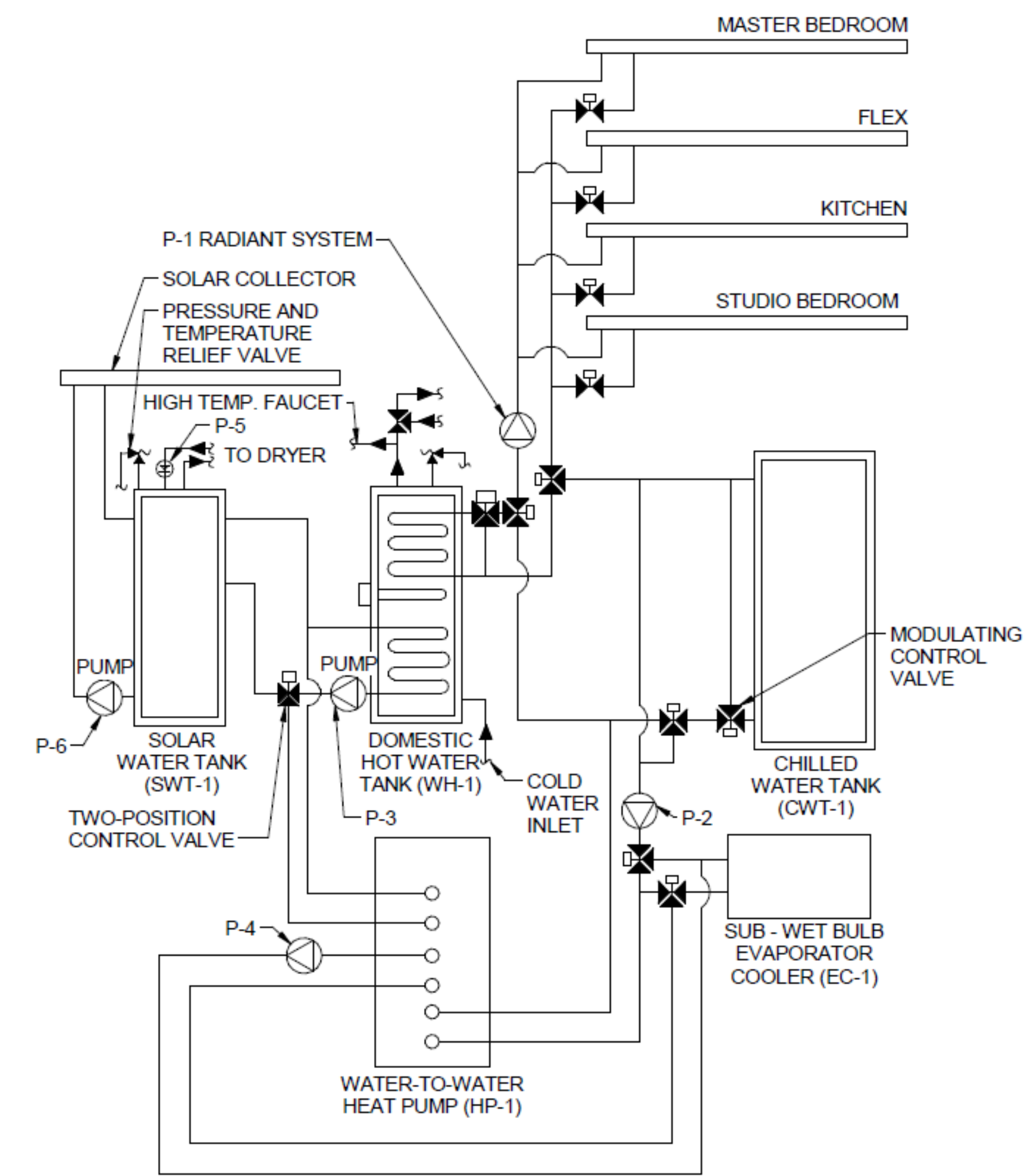

MECHANICAL DIAGRAM

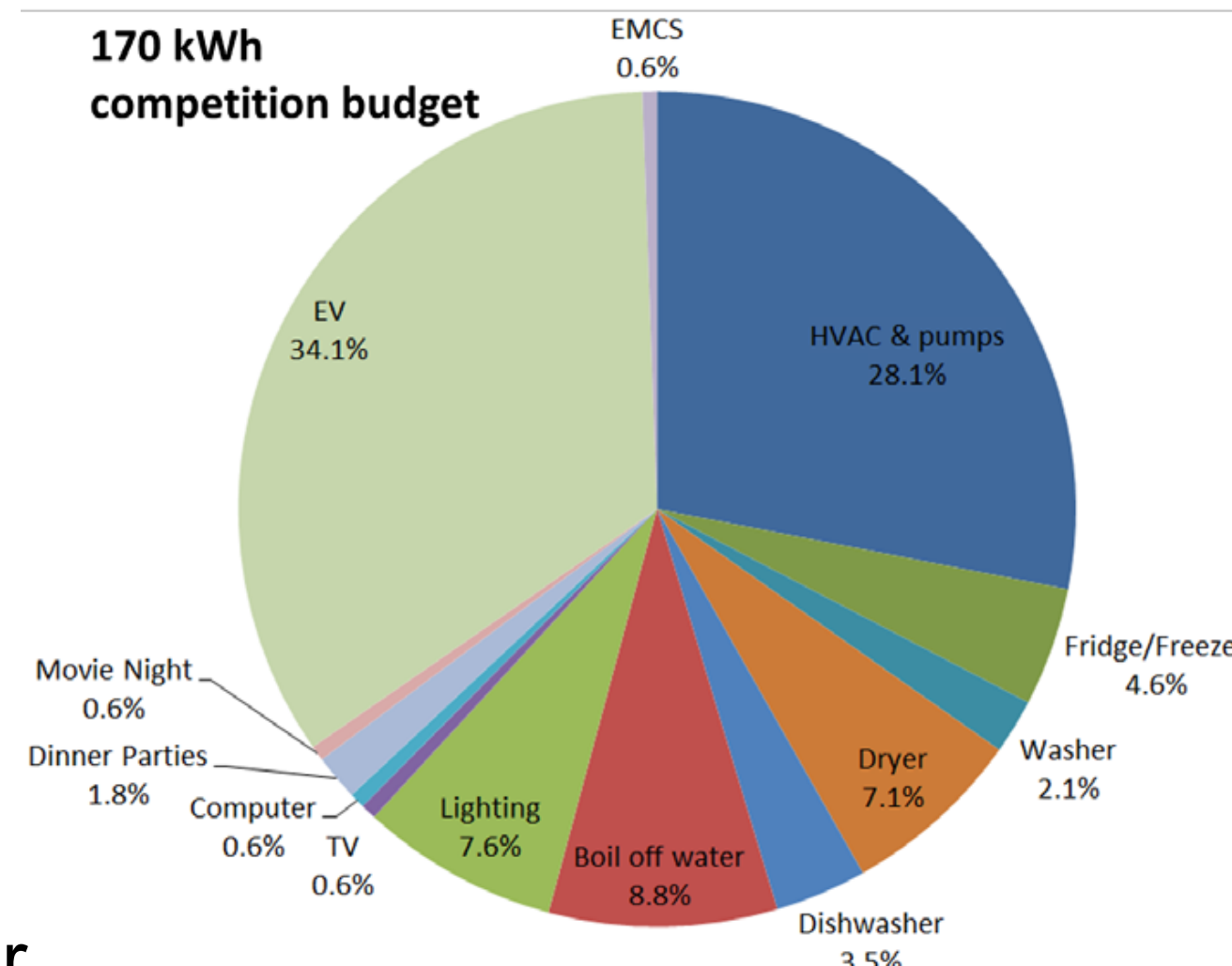

Advisors:

- Jack Brouwer - UCI Associate Professor
- Will Vicent - Project Manager at SoCal Edison
- Chris Tindall - Managing Principal at McParlane & Associates
- Moritz Limpinsel - Solar Decathlon project engineer

Contact Information:
 Alexander McDonald
 Project Manager
alexander.mcdonald@gmail.com
<http://www.teamoc2015.com>

